

Coaxial Adapter N Female to SMA Male

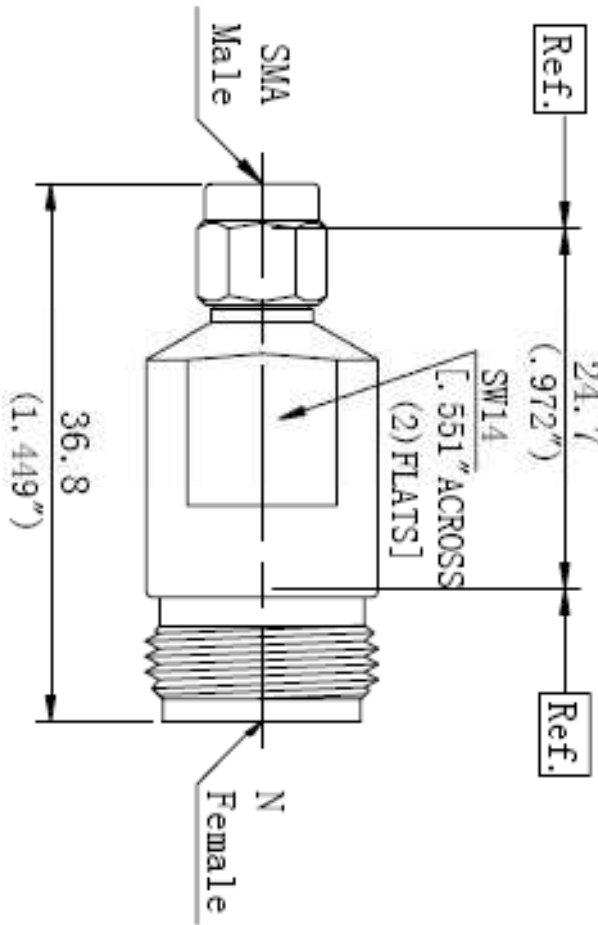

2.0 Environment specifications		
2.1	Opt. Temp.	-55°C~+165°C
2.2	Storage Temp.	-60°C~+185°C
2.3	Altitude	45000 ft
2.4	Vibration	10g rms (15 degree 2KHz)
2.5	Humidity	100% RH at 35c, 95%RH at 40 °c
2.6	Shock	20G for 11msc

1.0 Mechanical Specifications		
1.1	N	MIL-STD-348A
1.2	SMA	MIL-STD-348A
1.3	MIL	MIL-G-45204

PN	Frequency (GHz)	Impedance (Ω)	VSWR (max)	Insulate material	Material	Center PIN
RFAERNFSM	DC-18	50	1.15	PEI&PTFE	Stainless Steel SU303	Brass with Gold plating

PAGE 1 OF 1

DATE JAN 8th 2003

DESIGN RFPC

RF-LAMBDA RFPC

CAD MODEL REVISION 02-1

ASSEMBLY REVISION VS23

ASSEMBLY NAME RFLVR54

DRAWING NUMBER D02-12

www.rflambda.com

RF-LAMBDA

RF-LAMBDA
COAXIAL ADAPTER
RFAERNFSM

SIZE LT SHEETS 1 OF 1