



50 W 0.4-3 GHz 20dB Directional Coupler



- High power handle capability up to 50W
- Wide band operation
- High isolation within operational band
- Low Insertion loss
- Low temperature coefficient material offer stable performance over temperature
- Aerospace and military application
- LMDS multi-carrier operation
- High peak to average handle capability
- All specifications can be modified upon request

Electrical Specifications

Parameters		Min.	Typ.	Max.	Min.	Typ.	Max.	Units
Frequency Range		0.4		0.8	0.8		3	GHz
Nominal Coupling		19	20	21	19	20	21	dB
Frequency Sensitivity			±0.7	±1.0		±0.5	±0.7	dB
Directivity		20	23		20	23		dB
Insertion Loss (Excl Coupling)			0.3	0.4		0.4	0.5	dB
VSWR Primary			1.1	1.2		1.15	1.2	
VSWR Secondary			1.1	1.2		1.15	1.2	
Power Rating	Average	50						W
	Peak	0.3						KW
Impedance		50						Ohms
Operating Temperature		-45 to +85						°C
Weight		70						g
Input / Output Connector		SMA-Female						
Material		Aluminum						
Finishing		Gray Paint						

Coaxial 50W 0.4-3 GHz 10dB Directional Coupler



RF-LAMBDA

The power beyond expectations

RFDC4M3G20

Environment specifications

Operational Temperature (°C)	-45 to +85
Storage Temperature (°C)	-55 to +125
Altitude	30,000 ft. (Epoxy Seal Controlled environment) 60,000 ft 1.0psi min (Hermetically Seal Un-controlled environment) (Optional)
Vibration	25g rms (15 degree 2KHz) endurance, 1 hour per axis
Humidity	100% RH at 35c, 95%RH at 40 deg c
Shock	20G for 11msc half sin wave,3 axis both directions

Typical Performance Plots

Insertion Loss

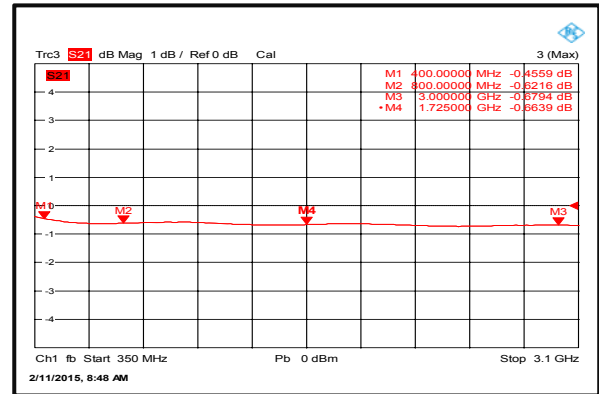

Primary VSWR

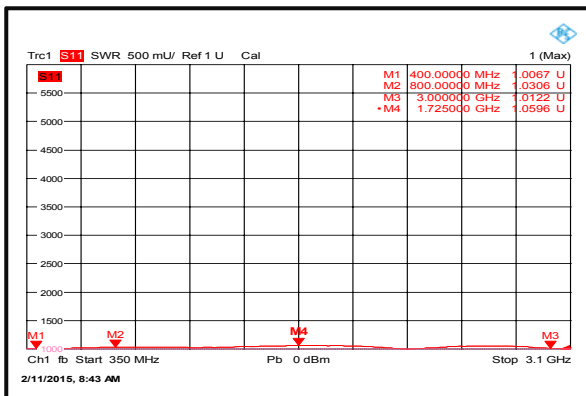

Secondary VSWR

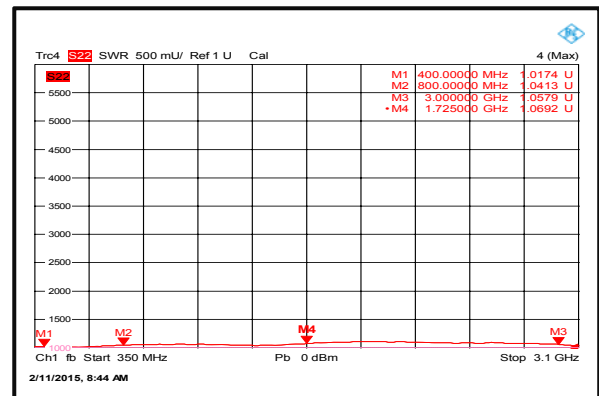

Directivity

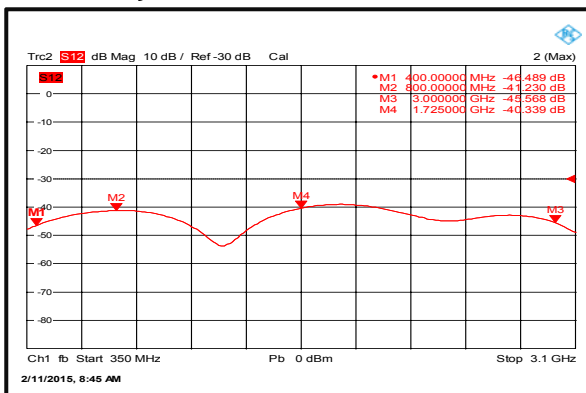

Coaxial 50W 0.4-3 GHz 10dB Directional Coupler



Outline Drawing:

All Dimensions in mm (inches)

Tolerance ± 0.25 (0.01)

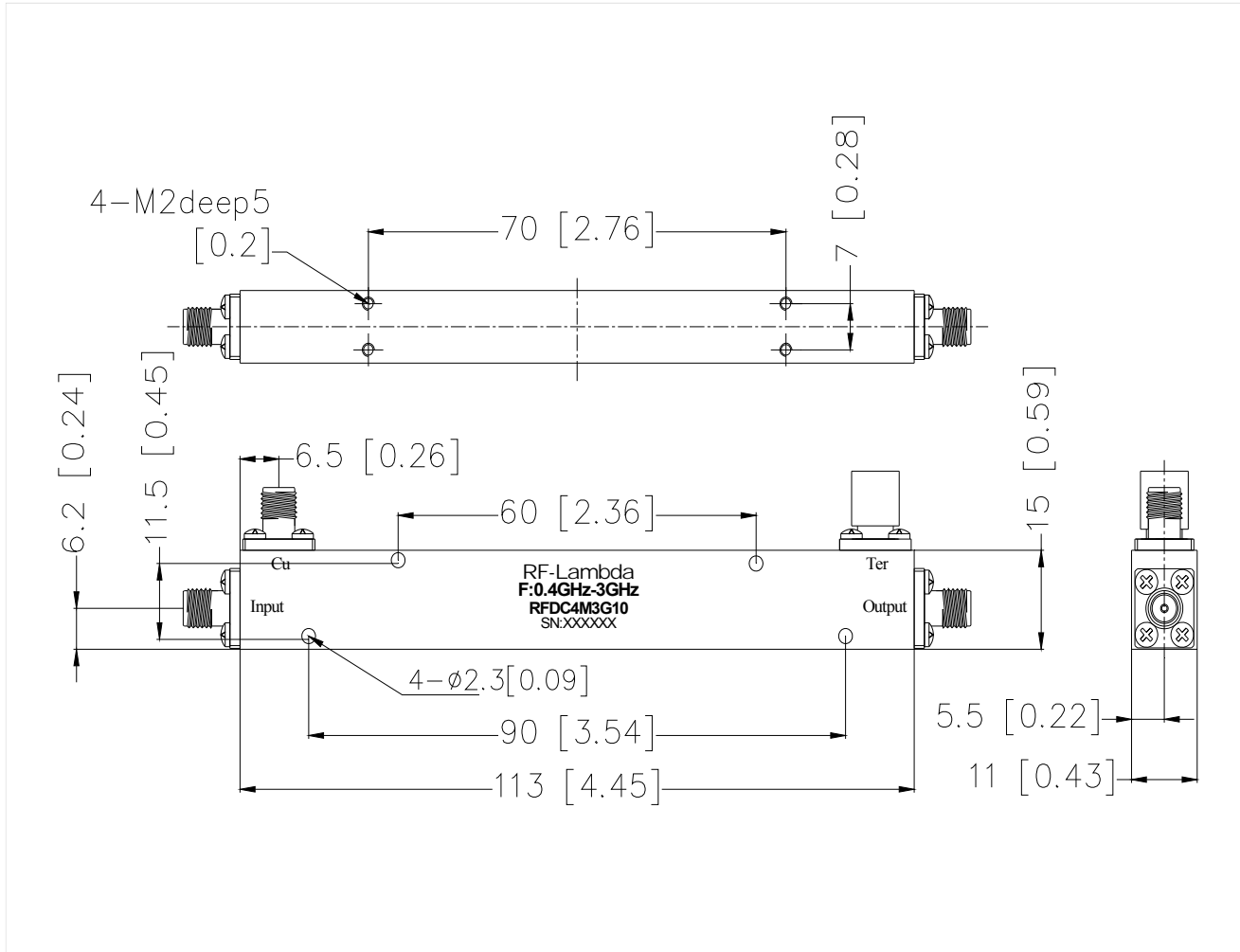

Important Notice

The information contained herein is believed to be reliable. RF-Lambda makes no warranties regarding the information contained herein. RF-Lambda assumes no responsibility or liability whatsoever for any of the information contained herein. RF-Lambda assumes no responsibility or liability whatsoever for the use of the information contained herein. The information contained herein is provided "AS IS, WHERE IS" and with all faults, and the entire risk associated with such information is entirely with the user. All information contained herein is subject to change without notice. Customers should obtain and verify the latest relevant information before placing orders for RF-Lambda products. The information contained herein or any use of such information does not grant, explicitly or implicitly, to any party any patent rights, licenses, or any other intellectual property rights, whether with regard to such information itself or anything described by such information. RF-Lambda products are not warranted or authorized for use as critical components in medical, life-saving, or life sustaining applications, or other applications where a failure would reasonably be expected to cause severe personal injury or death.